

# INSTALLATION INSTRUCTION

## AETHER ATOMIC - TRIMLESS DOWNLIGHT, PINHOLE, WALL WASH

R1ARRL, R1ASRL, R1ABFL



### WARNING:

IMPORTANT: NEVER attempt to do any work without shutting off the electricity.

- Read all instructions before installing.
- System is intended for installation by a qualified electrician in accordance with the National Electrical Code and local regulations.
- Go to the main fuse box, or circuit breaker. Place the main power switch in the "OFF" position and unscrew the fuse(s) or switch "OFF" the circuit breaker switch(es) that control the power to the fixture or room that you are working on.
- Place the wall switch in the "OFF" position.

### AVERTISSEMENT:

IMPORTANT: Coupez l'électricité avant TOUTE manipulation.

- Lisez toutes les instructions avant d'installer.
- Système est destiné à être installé par un électricien qualifié en conformité avec le code national de l'électricité et les règlements locaux.
- Accédez au panneau central de disjoncteurs ou de fusibles de votre demeure et placez l'interrupteur principal en position d'arrêt (« OFF »).
- Placez l'interrupteur mural en position d'arrêt (« OFF »).

### CAUTION:

All parts must be used as indicated in these instructions. Do not substitute any parts, leave parts out, or use any parts that are worn out or broken. Failure to follow this instruction could invalidate the ETL/cETL listing of this fixture.

### OVERVIEW:

Housing is for IC Airtight remodel and new construction applications. Housing requires a remote power supply to power the LED and a trim for a finished look. Refer to specification sheets for compatible remote power supply and trim options .

### OVERALL HOUSING DIMENSION

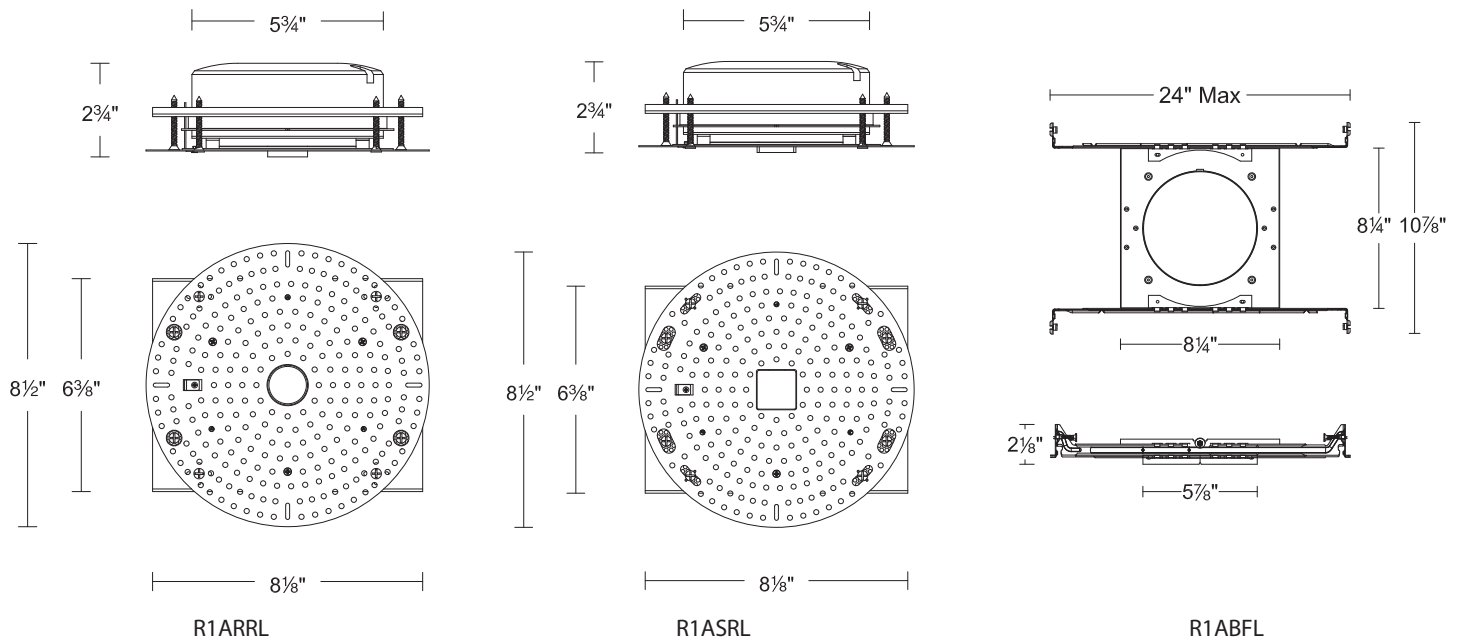

SPECIFICATIONS	
Input	DC 18V, 600mA Constant Current
Ceiling Thickness	1/2" - 2"

Installation Type	Ceiling Thickness	Minimum Required Ceiling Plenum Height
New Construction	1/2" - 2"	3"
Remodel	1/2"	3 1/2"
	1"	4 1/2"
	2"	5 1/2"

wacighting.com

Phone (800) 526.2588

Fax (800) 526.2585

Headquarters, East Manufacturing Facility

44 Harbor Park Drive

Port Washington, NY 11050

South East Manufacturing Facility

1600 Distribution Ct

Lithia Springs, GA 30122

Central Manufacturing Facility

1700 South J Elmer Freeway, Ste 100

Cedar Hill, TX 75104

West Manufacturing Facility

1750 S Archibald Ave

Ontario, CA 91761

# INSTALLATION INSTRUCTION

## AETHER ATOMIC - TRIMLESS DOWNLIGHT, PINHOLE, WALL WASH

R1ARRL, R1ASRL, R1ABFL



### REMODEL INSTALLATION

1. Cut out a 6 1/2" diameter hole on drywall ceiling using a proper tool (See FIG. 1).
2. Take out the ceiling mounting plate included in the housing package. Press the plate against the ceiling from below, with the collar of the plate inserted inside the cutout hole. Center the collar about the cutout hole. (See FIG. 2).

Rotate the ceiling mounting plate along the cutout hole, using the two rectangular slots on the plate as an axis to align the plate. Draw two short lines inside the two slots using a pencil. If you are installing a square housing (R1ASRL-\*), these two short lines will serve as the axis to align the square downlight trim or pinhole. Mark four dots using the pencil at locations shown in Figure 2 (See FIG. 2).

3. Flip the ceiling mounting plate along the axis connecting the two slots to let the collar face downwards. Place the plate on top of the drywall ceiling by passing through the cutout hole (See FIG. 3).

4. Ensure the collar fits inside the cutout hole and is centered. Align the mounting plate's rectangular cutout and V-shaped notch with the two short lines marked on the ceiling (done in Step 2) (See FIG. 4A). Hold the plate tight against the ceiling with one hand and fasten drywall screws (included with the housing) through the four dots (marked on drywall in Step 2), into the plate above. (See FIG. 4B).

5. Take out the housing body and connect two wire leads from the remote power supply using two WAGO connectors pre-installed on housing wire leads (See FIG. 5). Refer to remote power supply instruction for fixture and dimmer wiring.

**CAUTION:** Do not power fixture with foam plug installed or damage may result. Remove plug and keep for future installation if wish to power at this step.

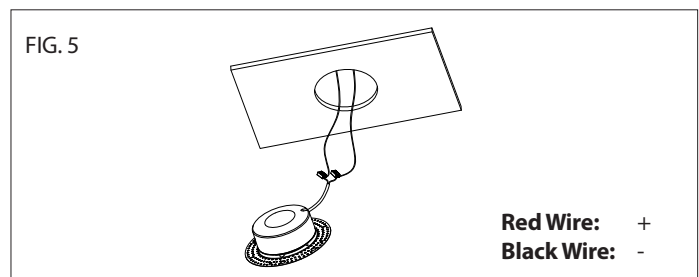
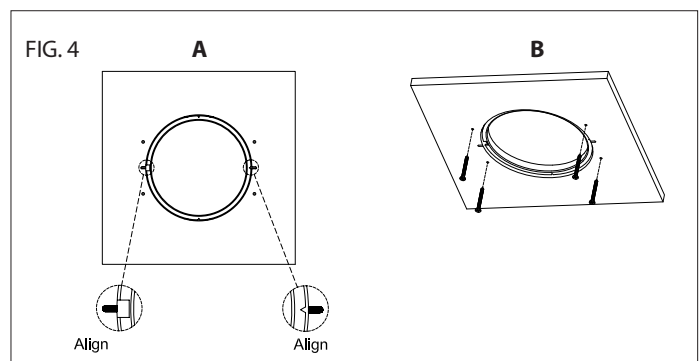
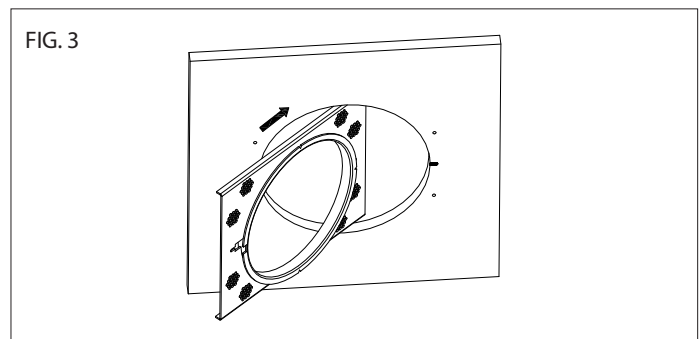
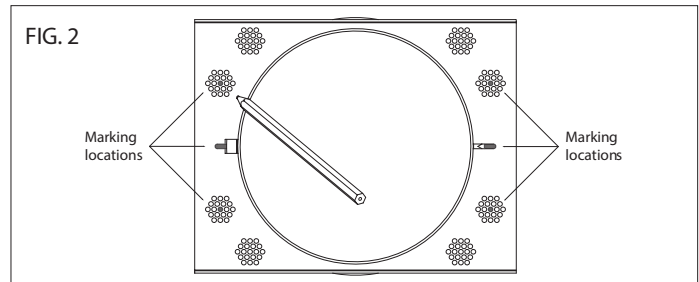
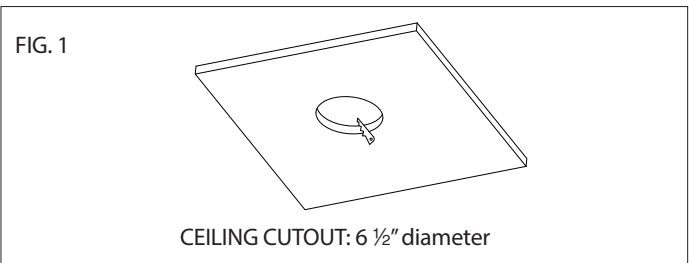

wacighting.com  
Phone (800) 526.2588  
Fax (800) 526.2585

Headquarters, East Manufacturing Facility  
44 Harbor Park Drive  
Port Washington, NY 11050

South East Manufacturing Facility  
1600 Distribution Ct  
Lithia Springs, GA 30122

Central Manufacturing Facility  
1700 South J Elmer Freeway, Ste 100  
Cedar Hill, TX 75104

West Manufacturing Facility  
1750 S Archibald Ave  
Ontario, CA 91761

# INSTALLATION INSTRUCTION

## AETHER ATOMIC - TRIMLESS DOWNLIGHT, PINHOLE, WALL WASH

R1ARRL, R1ASRL, R1ABFL



6. Insert the housing body inside the ceiling opening and rotate the housing until the positioning pin on the housing fits inside the rectangular cutout on the ceiling mounting plate. Press the trimless frame of the housing against the ceiling and fasten four drywall screws (included with the housing) at four countersink holes (round housing, R1ARRL-\*) or curved slots (square housing, R1ASRL-\*) on the trimless frame to mount the housing to the ceiling (See **FIG. 6**).

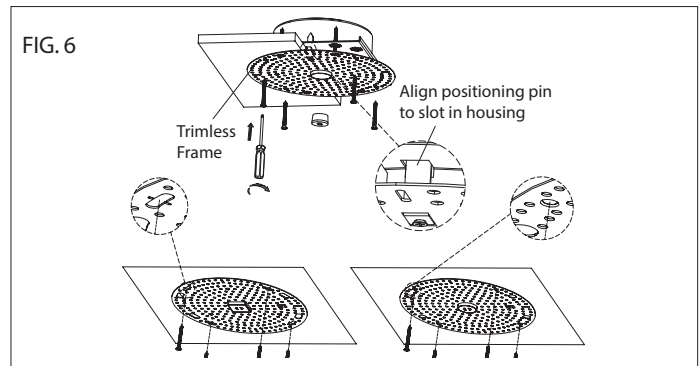

7. To make fine adjustments in alignment for square housing, use a Phillips screw driver to remove the positioning pin from the trimless frame, slightly loosen four mounting screws, and rotate the housing to achieve the desired alignment (See **FIG. 7**).

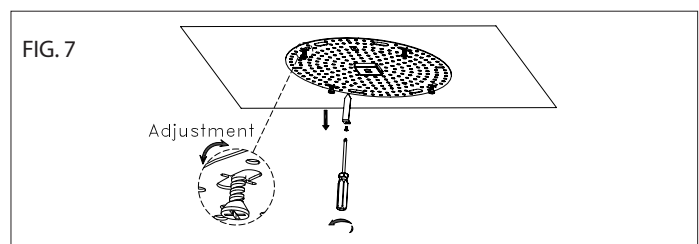

8. Ensure the foam plug covers the housing collar opening with its bottom surface flush with the collar edge. Apply plaster or spackle over trimless frame and sand surface when dry for a finished look (See **FIG. 8**).

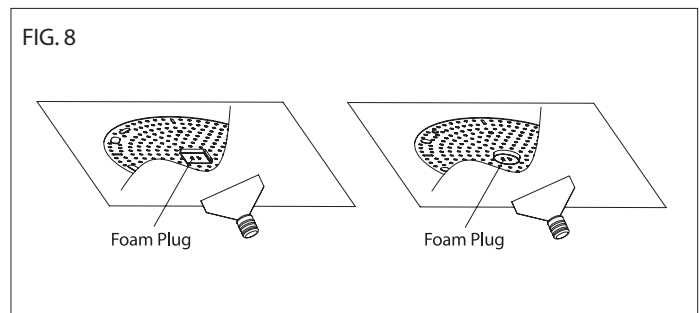

9. Paint the ceiling evenly, also covering the housing opening and plug. Gently cut through the paint along the internal edge of the round or square collar with a small knife (See **FIG. 9**).

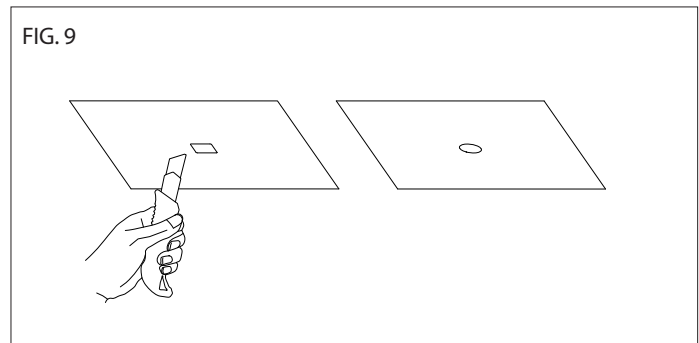

10. Grip the center of the foam plug with a pair of pointed pliers and gently pull it down to remove it from the housing collar (See **FIG. 10**).

NOTE: To achieve a sharp and clean aperture, gently remove loose paint chips and clean up small debris along the collar edge using a damp soft cloth. Touch up any uncovered surfaces along the collar edge with the ceiling paint using a small brush.

11. Install the trim and reflector assembly by gently pushing it inside the housing collar opening. Ensure the bottom of the trim is flush with the ceiling surface (See **FIG. 11**).

Refer to "INSTALLATION OF REFLECTOR ON TRIM" Section for installing reflector on trim.

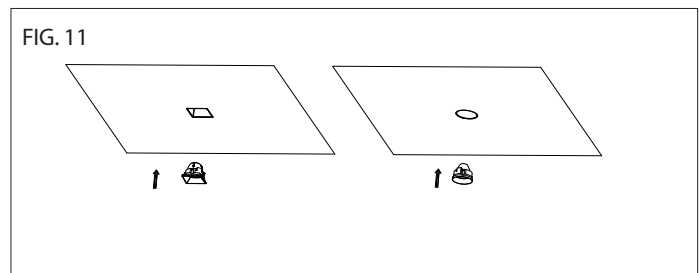
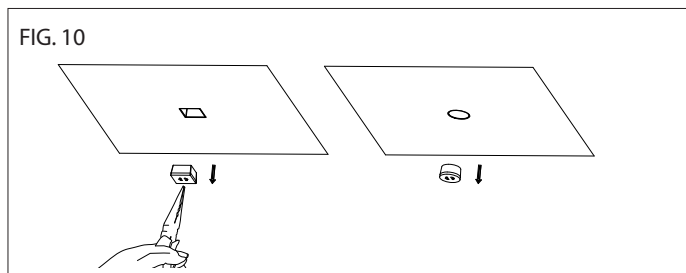

wacighting.com

Phone (800) 526.2588

Fax (800) 526.2585

Headquarters, East Manufacturing Facility

44 Harbor Park Drive

Port Washington, NY 11050

South East Manufacturing Facility

1600 Distribution Ct

Lithia Springs, GA 30122

Central Manufacturing Facility

1700 South J Elmer Freeway, Ste 100

Cedar Hill, TX 75104

West Manufacturing Facility

1750 S Archibald Ave

Ontario, CA 91761

# INSTALLATION INSTRUCTION

## AETHER ATOMIC - TRIMLESS DOWNLIGHT, PINHOLE, WALL WASH

R1ARRL, R1ASRL, R1ABFL



### NEW CONSTRUCTION INSTALLATION

(With Optional Frame-In Kit **R1ABFL**)

1. Install frame-in kit using two hanger bars (24" max) (See **FIG. 12**).
2. Hanger bars include a captive mounting "screw-nail" for ease of installation. Align the bottom of the hanger bar with the bottom of the wood joist. Secure the "screw-nail" on each end by screwdriver (See **FIG. 13A**), or by hammer (See **FIG. 13B**).
3. Slide fixture frame-in kit along bar hangers into desired location. Use locking screws to secure (See **FIG. 13C**).
4. To shorten hanger bars to fit in a 12" joist, snap off one section of the hanger bars (See **FIG. 14**).
5. Cut a 6" diameter hole in the drywall ceiling at the point of installation and install drywall ceiling (See **FIG. 15**).
6. Take out the housing body and connect two wire leads from the remote power supply using two WAGO connectors pre-installed on housing wire leads (See **FIG. 16**).

**CAUTION:** Do not power fixture with foam plug installed or damage may result. Remove plug and keep for future installation if wish to power at this step.

7. Insert the housing body inside the ceiling opening and rotate the housing until the positioning pin on the housing fits inside the rectangular cutout on the frame-in kit. Press the Trimless Frame of the housing against the ceiling and fasten four drywall screws (included with the housing) at four countersink holes (round housing, R1ARRL-\*) or curved slots (square housing, R1ASRL-\*) on the Trimless Frame to mount the housing to the ceiling (See **FIG. 17**).

Refer to Steps 7 to 11 in "**REMODEL INSTALLATION**" Section to complete installation.

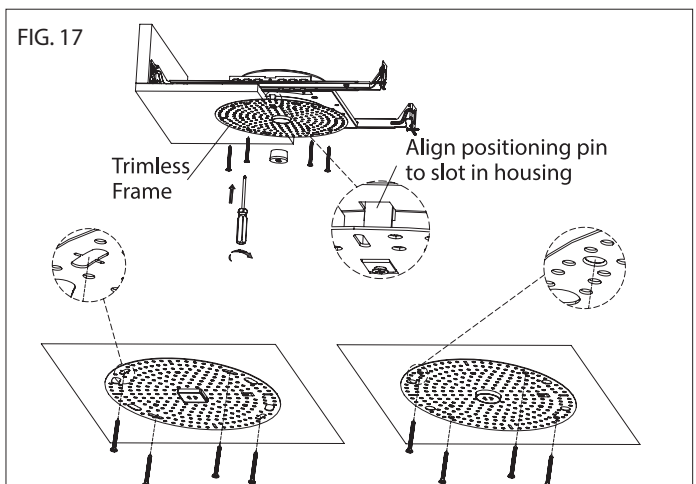
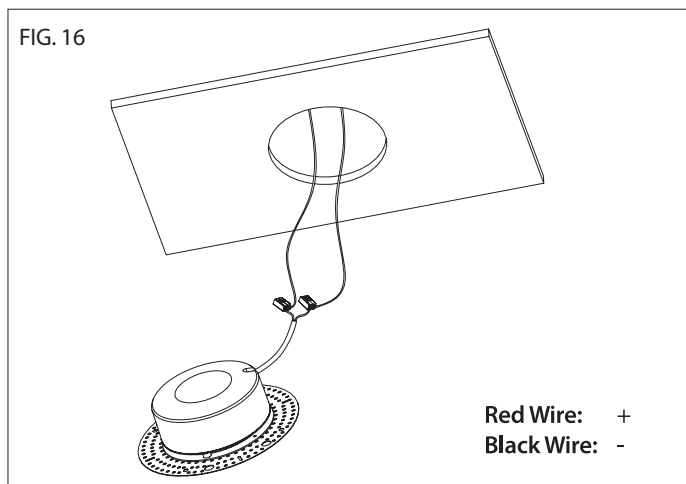
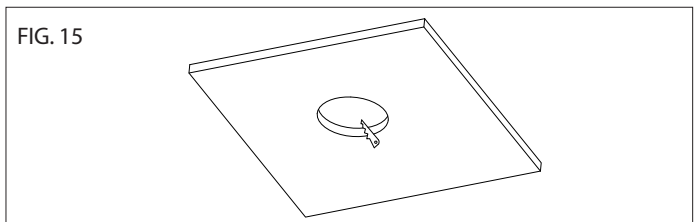
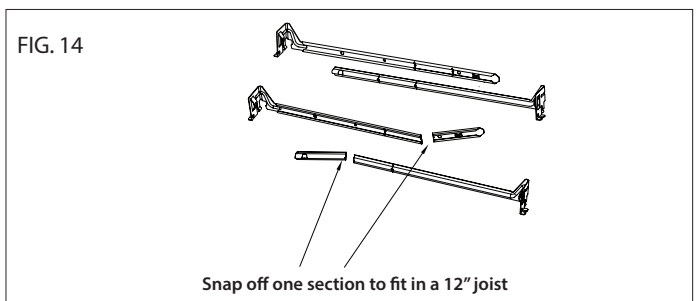
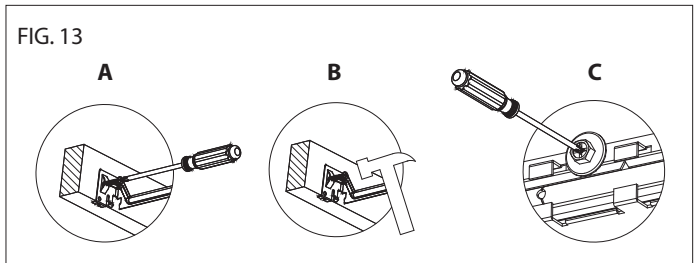
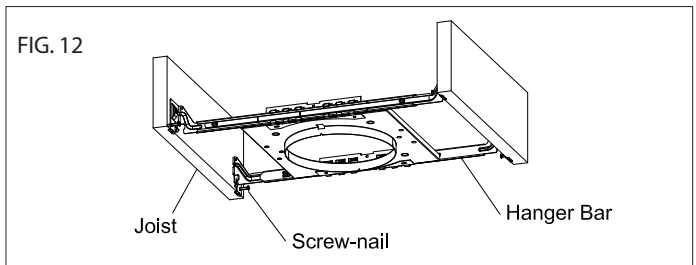

wacighting.com

Phone (800) 526.2588

Fax (800) 526.2585

Headquarters, East Manufacturing Facility

44 Harbor Park Drive

Port Washington, NY 11050

South East Manufacturing Facility

1600 Distribution Ct

Lithia Springs, GA 30122

Central Manufacturing Facility

1700 South J Elmer Freeway, Ste 100

Cedar Hill, TX 75104

West Manufacturing Facility

1750 S Archibald Ave

Ontario, CA 91761

# INSTALLATION INSTRUCTION

## AETHER ATOMIC - TRIMLESS DOWNLIGHT, PINHOLE, WALL WASH

R1ARRL, R1ASRL, R1ABFL



### INSTALLATION OF REFLECTOR ON TRIM

Choose the reflector with the desired beam angle and snap it on top of downlight trim or pinhole to install. Ensure the reflector fully engages with the clips at the top of trim or pinhole and is flush. (See **FIG. 18**. Note: While other reflectors are included in reflector package, only "F" reflector is shown in the figure). All wall wash trims have the reflector pre-installed in the factory.

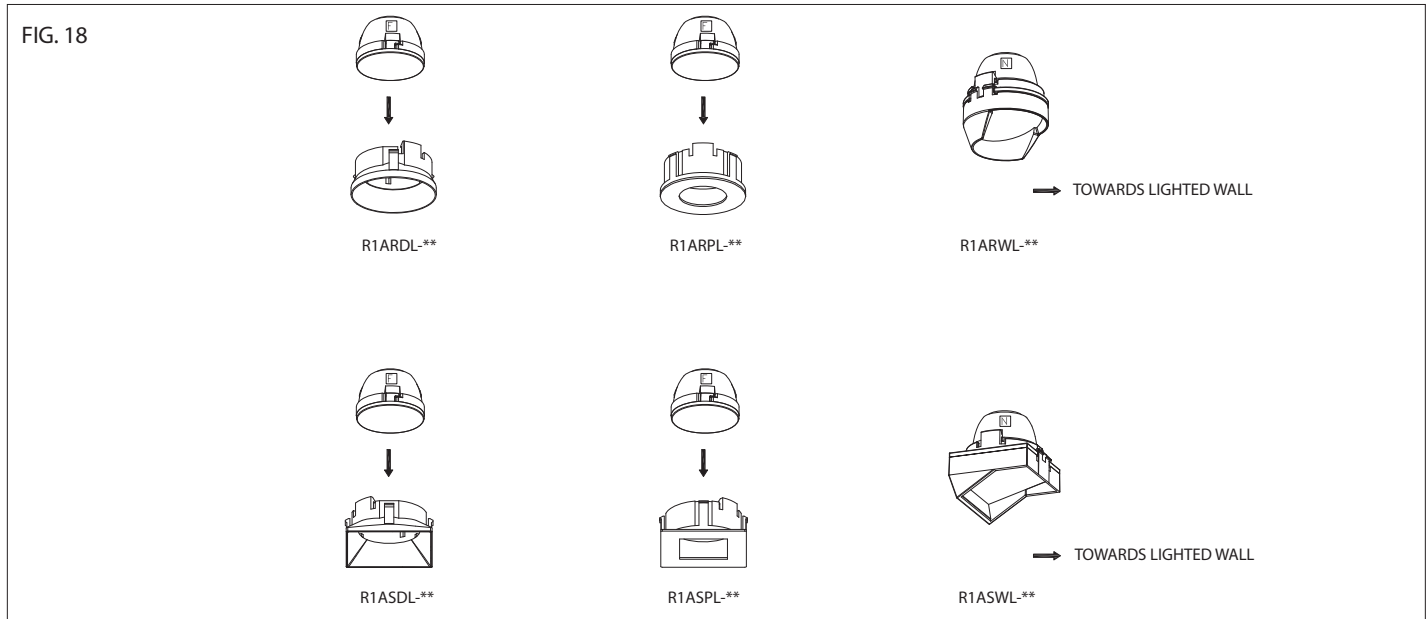

### SERVICING TRIM AND LIGHT ENGINE

(With Service Tool **R1A-TOOL**)

#### • Removing Trim

**Note:** Turn off power and let trim cool down before removing downlight, pinhole or wall wash trim.

Unscrew the top cylinder of service tool to expose the stainless steel hook. Place the tip of the hook into the gap between the bottom of reflector and the top of trim. Gently pull down to remove trim from the housing (See **FIG. 19**). To remove pinhole or wall wash trim, simply use finger to grip the edge of pinhole or the kicker of wall wash trim and gently pull it down to remove it from the housing.

#### • Replacing Light Engine

1. Remove the trim from the housing. Screw the top cylinder on the tool base. Locate two notches on edge of the LED holder inside the housing collar. Insert the tip of service tool inside the collar to have the two L-shape hooks travel through the two notches of the LED holder, then slightly turn clockwise to engage with two tabs of the LED holder. Gently pull the light engine down to separate magnets and to remove it from housing. Disconnect the wire connector to replace light engine (See **FIG. 20**).
2. Connect the new light engine to the wire connector, use finger to push wire leads back to the cavity of housing on side of the light engine receptacle. Be sure the wire leads do not tangle to block the receptacle of light engine. Use the service tool to gently insert light engine through the housing collar to let its base fully engaged with the magnet of the receptacle (See **FIG. 20**).

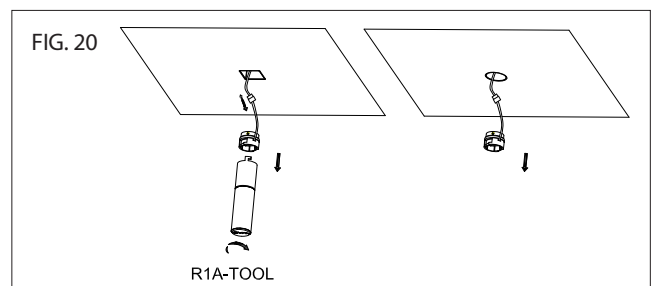
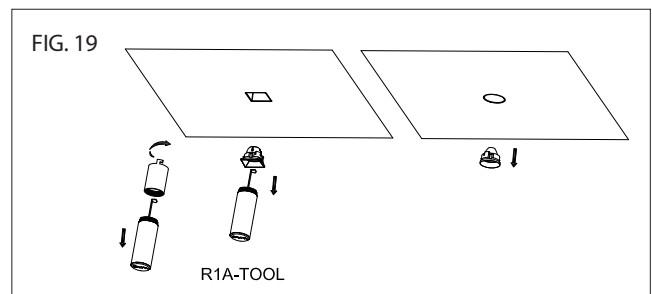

### REMOTE POWER SUPPLY WIRING

Refer to relative instructions of remote power supply for installation of power supply.

wacighting.com

Phone (800) 526.2588

Fax (800) 526.2585

Headquarters, East Manufacturing Facility

44 Harbor Park Drive

Port Washington, NY 11050

South East Manufacturing Facility

1600 Distribution Ct

Lithia Springs, GA 30122

Central Manufacturing Facility

1700 South J Elmer Freeway, Ste 100

Cedar Hill, TX 75104

West Manufacturing Facility

1750 S Archibald Ave

Ontario, CA 91761