

INSTALLATION INSTRUCTIONS

VENTRIX - Stealth Wall Wash

S2WW12, S2WW24, S2WW48

VENTRIX
BY WAC

CAUTION: TO PREVENT ELECTRICAL SHOCK, ENSURE ELECTRICITY HAS BEEN TURNED OFF AT THE CIRCUIT BREAKER BEFORE BEGINNING.

- Read all instructions before installing.
- System is intended for installation by a licensed electrician in accordance with the National Electrical Code (NEC) and local regulations.
- When handling the fixture, do not apply pressure to the LEDs. Hold the fixture by the base only.
- Retain installation instructions for future maintenance reference.
- VENTRIX fixtures and channels feature separate data and power conductor systems. During installation and use, do not short the data or power conductors together by any means or damage may occur.

WARNING: All parts must be used as indicated in these instructions. This product is designed for use only with the supplied parts and/or accessories designated for use by WAC Lighting. Substitution of parts or accessories not designated for use with this product by WAC Lighting could result in personal injury or property damage, and will void the warranty. Contact an authorized dealer or the manufacturer if any parts are damaged or missing.

MISE EN GARDE: POUR ÉVITER TOUT CHOC ÉLECTRIQUE, ASSUREZ-VOUS QUE LE DISJONCTEUR SOIT MIS HORS TENSION AVANT DE COMMENCER.

- Lisez toutes les instructions avant l'installation.
- Le système doit être installé par un électricien licencié conformément au code national de l'électricité (NEC), et également aux règlements locaux.
- Lors de la manipulation du luminaire, n'appuyez pas sur les LED. Tenez-le uniquement par la base.

ATTENTION: Toutes les pièces doivent être utilisées comme indiqué dans ces instructions. Ce produit est conçu pour être utilisé seulement avec les pièces et/ou accessoires fournis pour être utilisés avec les produits WAC Lighting. Remplacer des pièces ou accessoires non conçus pour ce produit WAC Lighting pourrait causer des dommages corporels ou matériels et pourrait également causer l'annulation de la garantie. Veuillez contacter un revendeur autorisé ou le fabricant si des pièces manquent ou sont endommagées.

OVERALL FIXTURE DIMENSIONS

S2WW12

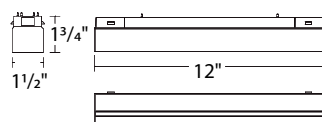

S2WW24, 48

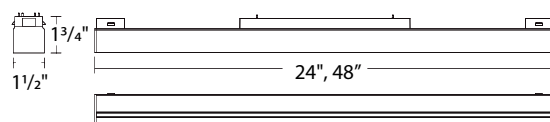

FIXTURE OVERVIEW

VENTRIX Stealth Wall Wash fixtures are intended for use on WAC Lighting's VENTRIX Channel systems.

LED LUMINAIRE	VENTRIX SYSTEM
S2WW12, S2WW24, S2WW48	48VDC VENTRIX System

SPECIFICATIONS	
Input:	48VDC
Installation:	VENTRIX System
Dimming:	Via VENTRIX Connected Power Unit. Refer to CPU Specifications.

CAUTION:	VENTRIX Stealth Wall Wash Fixtures are removable only by access to side releasing locking tabs. To enable fixture removal from channel: prior to installation, maintain free channel space of at least 1.5" on each side of adapter. Failure to do so may result in fixtures permanently installed in channel.
----------	--

wacighting.com

Phone (800) 526.2588

Fax (800) 526.2585

Headquarters, East Manufacturing Facility

44 Harbor Park Drive

Port Washington, NY 11050

South East Manufacturing Facility

1600 Distribution Ct

Lithia Springs, GA 30122

Central Manufacturing Facility

1700 South J Elmer Freeway, Ste 100

Cedar Hill, TX 75104

West Manufacturing Facility

1750 S Archibald Ave

Ontario, CA 91761

INSTALLATION INSTRUCTIONS

VENTRIX - Stealth Wall Wash

S2WW12, S2WW24, S2WW48

VENTRIX
BY WAC

PREPARATION:

1. Shut off the power at the circuit breaker and ensure adequate room to install the new fixture on the VENTRIX Channel system.
2. Carefully unpack your new fixture and lay out all the parts on a clear area. Be careful not to lose any parts necessary for installation.

FIXTURE INSTALLATION TO VENTRIX SYSTEM:

The fixture features a VENTRIX adapter for power and mechanical connection to the installed VENTRIX channel system.

1. This fixture may be installed into horizontally or vertically mounted VENTRIX channel systems. (See **FIG. 1**).
2. Fixtures are polarity agnostic, and may be installed in VENTRIX channel in either orientation. Orientate fixture in direction to aim light appropriately. (See **FIG. 2**)
3. Insert the fixture into the channel slot. Ensure the fixture is parallel to the channel during installation. Push the fixture into the channel until fully secured. **NOTE:** Fixture adapters also feature magnets to aid in fixture locating. (See **FIG. 3**).

CAUTION: Prior to installation in channel, clear any debris from channel bus bar and fixture, particularly on magnetic surfaces.

Any conductive elements have potential to cause electrical shorting resulting in damage.

4. Review connections and be sure both sets of locking tabs are secured in channel prior to finishing installation.

FIG. 1

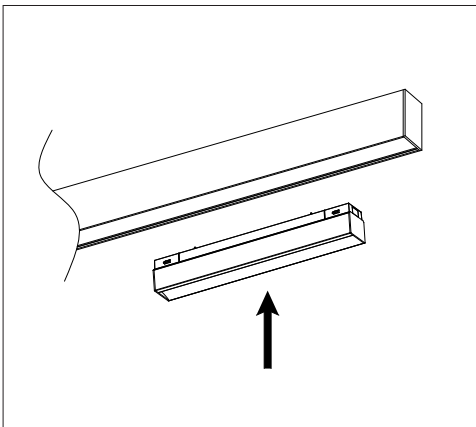

FIG. 2

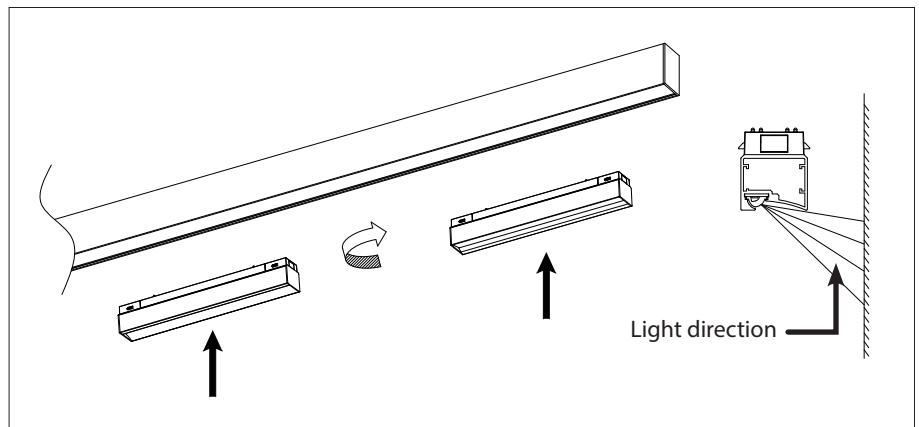
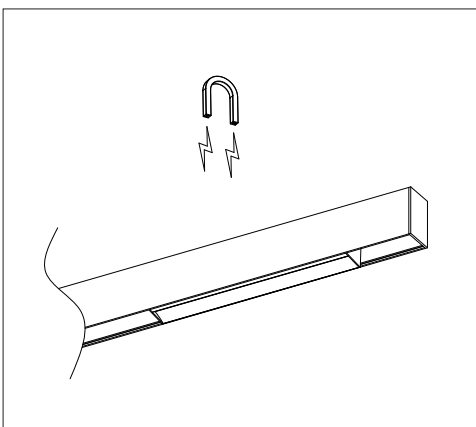

FIG. 3



wacighting.com

Phone (800) 526.2588

Fax (800) 526.2585

Headquarters, East Manufacturing Facility

44 Harbor Park Drive

Port Washington, NY 11050

South East Manufacturing Facility

1600 Distribution Ct

Lithia Springs, GA 30122

Central Manufacturing Facility

1700 South J Elmer Freeway, Ste 100

Cedar Hill, TX 75104

West Manufacturing Facility

1750 S Archibald Ave

Ontario, CA 91761

INSTALLATION INSTRUCTIONS

VENTRIX - Stealth Wall Wash

S2WW12, S2WW24, S2WW48

VENTRIX
BY WAC

RELOCATING THE FIXTURE IN CHANNEL:

While installed to the VENTRIX system, the fixture may be relocated. The fixture and channel may be powered ON or OFF during the relocation process.

1. By hand, relocate the fixture within a channel by pushing the adapter in the desired direction. (See FIG. 4).
2. Fixtures cannot be relocated between channels. It must be removed, reposition, and then installed from one channel to another. (See FIG. 5).

FIG. 4

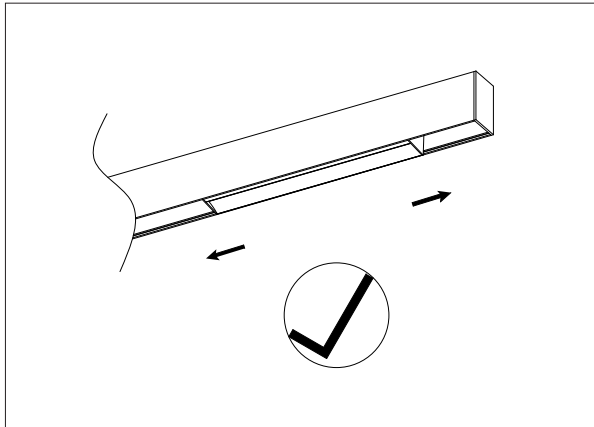

FIG. 5

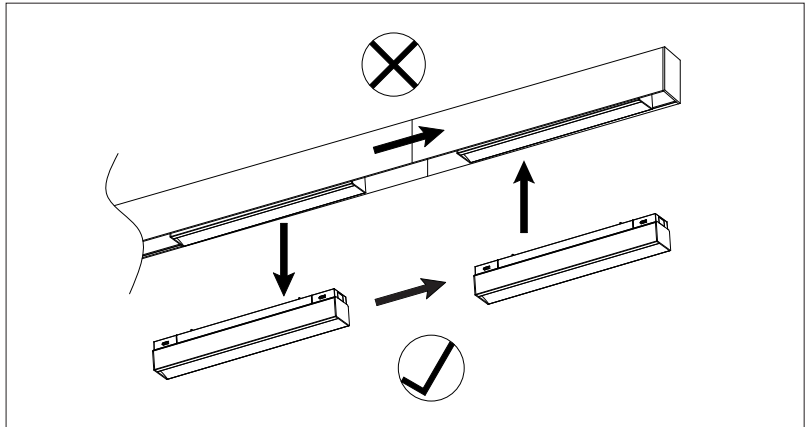
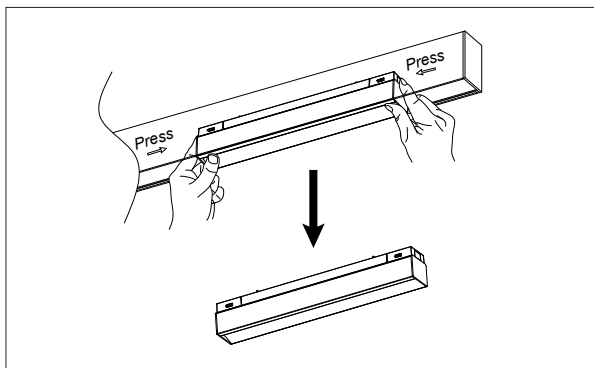

FIG. 6



REMOVING THE FIXTURE FROM THE CHANNEL:

1. By hand, engage and press both push buttons on the adapter. While both push buttons are pressed, pull the fixture away from the channel, until it is clear of the channel (See FIG. 6).

NOTE: Ensure the adapter is parallel to the channel during removal. (See FIG. 7).

2. To enable fixture removal from channel, maintain free channel space of 1.5" on each side of adapter to enable access to releasing locking tabs.

FIG. 7

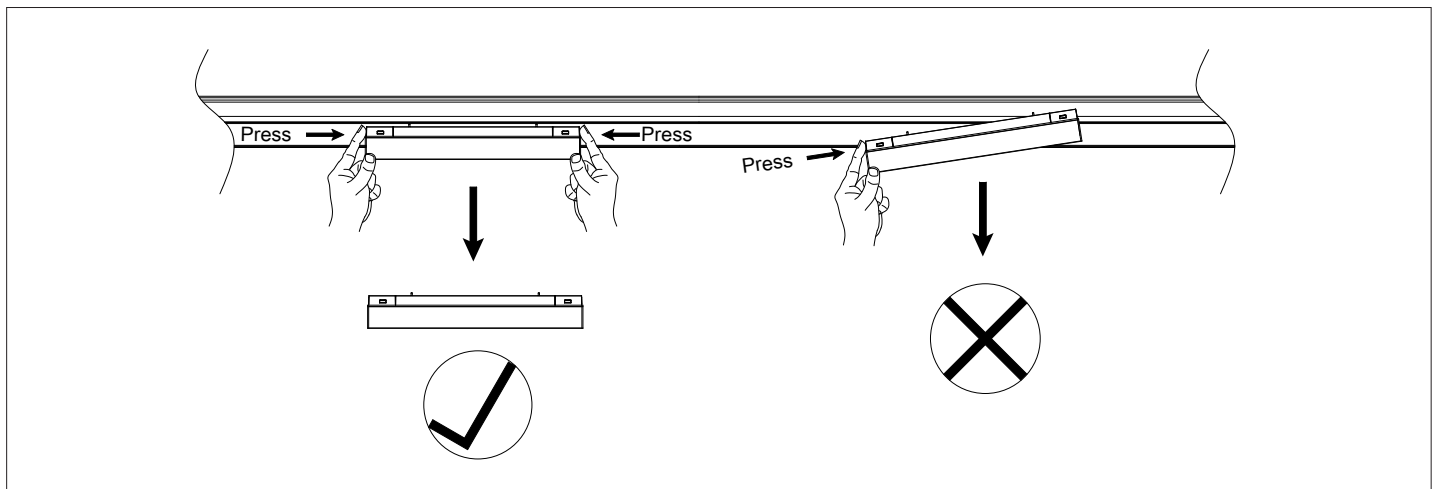

wacighting.com

Phone (800) 526.2588

Fax (800) 526.2585

Headquarters, East Manufacturing Facility

44 Harbor Park Drive

Port Washington, NY 11050

South East Manufacturing Facility

1600 Distribution Ct

Lithia Springs, GA 30122

Central Manufacturing Facility

1700 South J Elmer Freeway, Ste 100

Cedar Hill, TX 75104

West Manufacturing Facility

1750 S Archibald Ave

Ontario, CA 91761